



CASE STUDY /

## **Turbomeca Reduces Helicopter Engine Control Software Development Time with Ansys SCADE Suite**

“The Arrano 1A landed in Marignane after a flight of one hour and 25 minutes, reaching an altitude of 5,000 ft. and a speed of 150 kts. The engine control software of the ARRANO 1A was developed with Ansys SCADE Suite, and TURBOMECA thanks Ansys for its technical support and the professionalism that contributed to this major milestone.”

**Didier Bernard**

Head of Software System Group / Turbomeca

The engine control system is a critical part of helicopter engines. It controls fuel injection according to environment, use case and engine state, as well as other key engine functions. As they design new engines to match industry standards and the innovations of their helicopter-manufacturing customers, Turbomeca engineers have adopted a model-based design approach to quickly and efficiently develop the embedded software that runs the control system for each engine family.

### / Challenges

The model-based design approach adopted by Turbomeca engineers uses simulation tools for rapid prototyping, software testing and verification. However, the approach requires time-consuming manual coding, potentially introducing coding errors and inconsistencies between the code and the model. To keep pace with new innovations in helicopter and helicopter technology, and to remain compliant with DO-178B/C standards, they needed tools that helped them code more efficiently while reducing errors and improving code management.

### / Technology Used

Ansys® SCADE®

### / Engineering Solution

Turbomeca engineers developed the G4 software process that includes requirements management, model-based design, simulation, test automation and qualified code generation. They incorporated the SCADE Suite into the process because its efficient model checker enables them to run simulated test cases and detect problems early in the design phase. The suite's reusable symbol library promotes reuse and design consistency within and across software projects, and it helps reduce the time and cost of development by enabling software teams to use the same formal language and methods.

### / Benefits

Since they began using the G4 process with SCADE Suite for the Arriel and Arrano engine families, the development team has decreased the number of open problems on certified versions by 50% and reduced development time by 30%.

Turbomeca, part of the Safran group, is the world's leading producer of helicopter engines and has produced more than 70,000 engines since its founding in 1938. The company specializes in the design, production, sale and support of low- to medium-power gas turbines to power helicopters.



Arriel 2-D Engine.

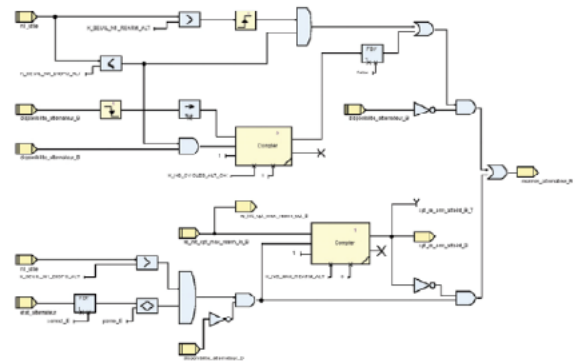

**ANSYS, Inc.**  
Southpointe  
2600 Ansys Drive  
Canonsburg, PA 15317  
U.S.A.  
724.746.3304  
ansysinfo@ansys.com

©2021 Ansys, Inc.  
All Rights Reserved.

[ansys.com](https://www.ansys.com)