

FAILURE MODES IN CONDUCTIVE ADHESIVES

By **Petri Savolainen**

Conductive adhesives offer lead-free, low temperature attachment for various types of electronics applications. They are composite materials consisting of a polymer matrix (adhesion, strength) and conductive filler (electric conductivity). Due to the nature of polymers, it is relatively easy to tailor adhesive properties to match specific requirements. Selection of the filler depends on the application.

Conductive adhesives have been used in the electronics industry for a long time. Silver-filled isotropic conductive adhesives (ICAs) were first used for die bonding in hybrid circuits. Many other applications have appeared since the introduction of ICAs. Anisotropic conductive adhesives (ACAs) were developed for attaching driver circuits to liquid crystal displays (LCDs) for calculators. Today, ACAs are a cornerstone for the display industry allowing the use of chip-on-glass and chip-on-flex technologies and enabling fast, reliable, and lightweight solutions for driving the displays.¹ ICAs are used in various applications from die attach to space applications.

In order to utilize the full potential of conductive adhesive in an application, it is very important to understand the limitations of the technology, especially the potential failure modes that may occur. With this knowledge, it is possible to proactively design and build a product cost effectively while also meeting reliability targets. It is essential that the reliability target is well defined and that the loads during the product's life are understood.

/ CONDUCTIVE ADHESIVE TYPES

In this section, the basic features of the two main types of conductive adhesives are discussed.

Anisotropic Conductive Adhesives (ACA)

ACAs are composite materials consisting of a polymer matrix and conductive particles. The volume fraction of conductive particles varies between 0.5-5%. Typically, the particles are polymer spheres coated with metal, but solid metal particles and solder particles are also used.² Figure 1 shows a schematic view of an ACA interconnection. The polymer matrix can be a thermoplastic or thermosetting polymer, the latter being more popular due to its higher bonding strength and reliability.

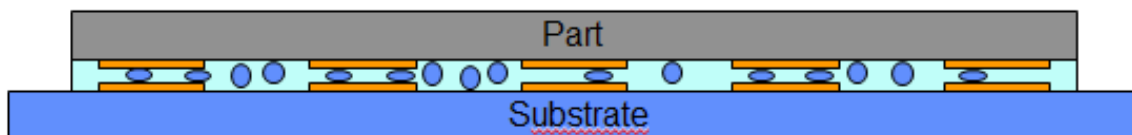

Figure 1: Schematic of ACA interconnection with deformable particles.

The function of the matrix is to keep the parts together as long as required as well as to insulate in the xy-plane of the adhesive. Consequently, good adhesion and high reliability is needed in addition to the insulation capability. Epoxy resins exhibit strong adhesion to a variety of substrates and have high glass transition temperatures. Therefore, they are popular matrix choices.

The curing is done using a thermo-compression process. Heating decreases the viscosity of the polymer matrix and makes it flow under the compression. Moreover, the heat is essential to cure the polymer during the process. Pressure pushes the conductive filler particles against the pads ensuring tight mechanical contact. The pressure is vital for the metal-coated polymer balls as they must be deformed during the process in order to take advantage of their compliant nature to maintain contact to the pads during temperature excursions.

Isotropic Conductive Adhesives (ICA)

ICAs contain between 20 and 35% conductive filler, usually silver. The size of the silver flakes ranges between 20 and 75 micrometers (μm), with the smaller flakes providing better application (screen printing, dispensing) properties, more homogenous composition, and larger electric contact area. Silver nanoparticles are a recent trend to enhance the adhesive properties.³

The polymer matrix is usually epoxy or epoxy-based resin. Adhesives are cured with heat, infrared, or ultraviolet radiation. The variation in cure cycle times is large and depends heavily on temperature, radiation level in the case of infrared or ultraviolet, and on the choice of polymer.

The conductivity of ICA results from the mechanical contact the filler particles make between each other and to the pads to be connected, as shown in Figure 2.⁴ Although silver oxidizes rapidly, its oxide is conductive. The compressive force resulting from the curing shrinkage of the polymer matrix maintains proper contact.

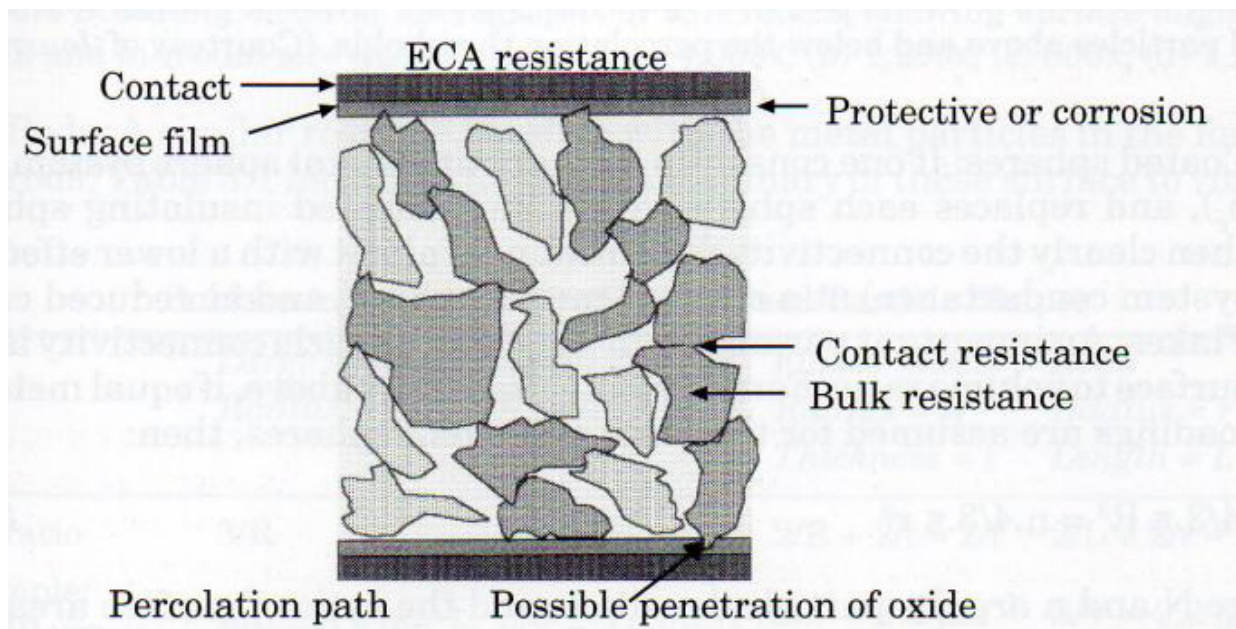

Figure 2. Electrical resistance elements in ICA.

/ FAILURE MODES

There are basically two failure modes with conductive adhesives: they do not conduct (open) or they conduct to the wrong direction (short).

Open circuit failures

The following items increase the interconnection resistance and eventually cause an open circuit.

Delamination - Delamination which occurs with both ICAs and ACAs, weakens the mechanical strength of the interconnection. A more abrupt sign is the loss of electrical conductivity of the interconnection which shows up first as an increase in resistance. This may also show as intermittent performance issues at the temperature extremes before the interconnection fails completely.

Poor adhesion is one cause of delamination. This may arise from incorrect selection of the polymer in terms of compatibility to the substrate. Another reason for poor adhesion comes from the process; substrates which are not cleaned properly leave residues of grease, sweat, etc., on the substrate preventing the adhesive from making good contact. Moisture ingress to the polymer may cause adhesion loss by weakening the bonds between the polymer and the substrate.

Mechanical stress may cause delamination of the adhesive interconnection. This is likely to be a more abrupt failure than one due to poor adhesion. The designer must understand the stress levels and design the adhesive joint accordingly with an appropriate safety margin.

Countermeasures for delamination are simple. Cleanliness in processing the adhesive interconnection is extremely important. Ensure that dust, fluids, and residues do not enter the interconnection area and ensure proper cleaning before applying the adhesive. An understanding of the expected mechanical loads is important for deciding the dimensions of the adhesive interconnection. Moreover, the loads to the adhesive shall be shear loads. Pull and especially peel loads should be avoided.

Polymer degradation: Moisture will diffuse into polymers in suitable conditions. It is highly likely that electric devices will be used in environments where humidity reaches levels where moisture ingress occurs. Water can degrade polymers by reacting with them. Liu et. al. have shown that water causes hydrolysis of the ester linkages in an ACA, producing hydroxyl and carbonyl end groups.⁵ The glass transition temperature (T_g) of the adhesive may decrease which in turn increases the risk of thermally induced damage. In addition, the water may act as a plasticizer which reduces the mechanical strength of the adhesive.

An adequate degree of cure is important in preventing moisture related failures. This will not eliminate the risk completely but can contribute to the lifetime in such a way that the reliability requirements are fulfilled. If needed, additional protective coatings may be used to further decrease the risk.

Polymer Swelling/Expansion: If the polymer matrix expands, resistance over the interconnection increases and the risk of losing contact grows. The polymer expansion may be caused by: 1) moisture ingress, and 2) thermal expansion. In both cases, the compressive force on the conductive particles will weaken. If the fillers are functioning as mechanical contact only, as the silver flakes in ICA or nickel particles in ACA, the contact resistance will very likely increase causing failure to the function of the device.

Water will diffuse into the polymer filling in empty spaces between the molecule chains. Consequently, the volume of the adhesive grows decreasing the pressure and thus increasing the resistance. When the polymer dries, the swelling disappears returning the resistance to normal levels.

Thermal expansion can produce similar effects especially if the temperature excursion exceeds the T_g of the polymer. When the temperature decreases below the T_g , the effect disappears. Continuous thermal cycling over the T_g can produce permanent changes in ICAs. For ACAs filled with metal-coated polymer particles, polymer expansion can cause high resistance or even opens if the particles have not been compressed during the process to a required level as in Figure 3. The main factor is to retain compliance.

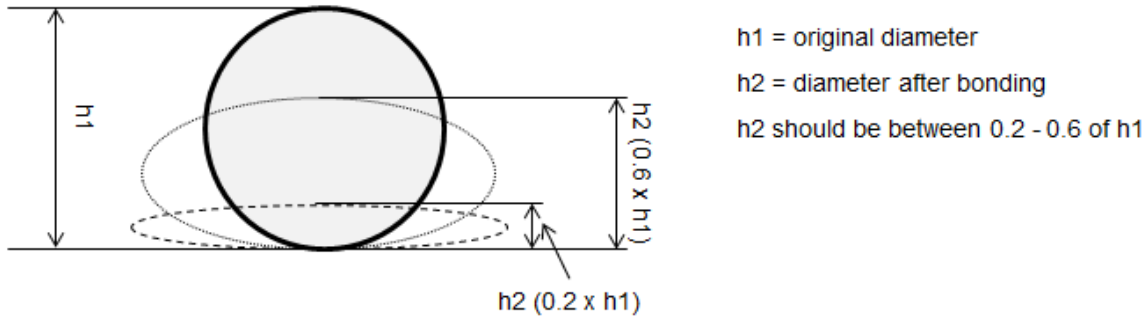

Figure 3: Recommended degree of compression for a conductive particle to ensure compliance

A high degree of cure is essential to minimize the moisture effects and is essential to protect against thermally induced swelling. The curing process has a significant impact on T_g . Moreover, the designer should be aware of the usage temperatures of the system as this allows selecting an adhesive with a high enough T_g . For ACA applications, using the compliant metal-coated polymer particles will enhance the interconnection's capability to retain low resistance in humid environments as well as during thermal cycling.

A challenge in detecting this kind of failure in thermal cycling testing is that the first failure may occur much earlier than the measurements at room temperature show.⁶ The test circuit may be open at the temperature extremes but work perfectly at room temperature. Therefore, it is essential that testing is performed using an event detector that measures the circuit in real time all the way through the cycling.

Oxidation: In the systems where less noble metals such as silver, nickel, or tin-based alloys are used, oxidation can cause problems for adhesive interconnections. The filler particles in the adhesive, for example silver in ICA or nickel in ACA, are prone to oxidation and depending on the system this can be a problem. On the other hand, if component terminations or pads on the substrate are coated with tin-lead or tin-silver, oxidation may impact the reliability.⁴

Filler Movement - It has been observed that if an ICA interconnection is thermally cycled over its T_g , the silver flakes may start to segregate. In time, this creates an open circuit as the particles move away from the other pad. Two conditions are essential for segregation to occur. One is the cycling over the T_g of the ICA. This results in high stresses in the ICA interconnection. The second condition occurs when a rigid component, e.g. chip resistor, is attached to a flexible substrate. The differences in the coefficients of thermal expansion (CTE) raise the stress levels so high that deformation of the ICA occurs.

One very simple solution exists for this problem: do not design your circuit or device to run at temperatures above the T_g of the ICA. If this is the case, look for ICAs meant for higher temperatures. Alternatively, you may try a redesign for lower use temperatures.

Air Bubbles - Figure 4 shows an example of a large air bubble within an ACA interconnection. The interconnection may work well electrically for a long time. However, there are related risks with such entrapments. They may retain moisture that diffuses into the ACA in use. Eventually the moisture can short circuit the connection and malfunction of the device will occur. Moreover, the air bubble decreases the mechanical strength of the adhesive, making it less resistant to mechanical loads. If the bubble resides at the bump/pad interface, it can cause an open due to the lack of conductive particles.

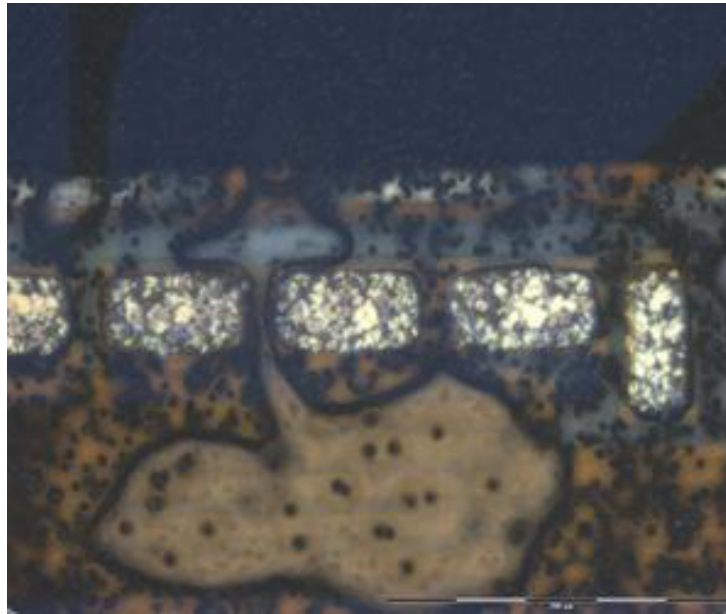

Figure 4: Large air bubble in a chip-on-glass anisotropic conductive film (ACF) interconnection.

The main reasons for air bubbles are too high of a heating rate and an inadequate amount of ACA. If the heating rate is too rapid, the polymer flow may be disturbed resulting in a bubble. Where there is not enough polymer, for example in the case of too thin ACF, the polymer will not fill the whole volume as it should.

Carefully defined process parameters (temperature, pressure, time) are essential to avoid air bubbles. Additionally, the thickness of anisotropic conductive film or the amount of anisotropic conductive paste must be such that the whole interconnection volume is filled properly.

Short Circuit Failures

In some cases, a connection between adjacent circuits is made resulting in a short circuit and device malfunction.

Electrochemical Migration - Silver, voltage, and moisture are a combination prone to electrochemical migration. Isotropic conductive adhesives with silver filler may encounter conditions enabling silver migration. However, there is one factor that has a limiting effect to migration if the conductive adhesive interconnection has been properly produced. The polymer matrix should be a good barrier for silver ion movement. Studies have proven this as they show that very high voltages and extreme conditions are required to induce silver migration in ICA interconnections.⁷ Therefore, in most cases the risk is minimal.

Ansys has found that, in some cases, migration has occurred even with relatively low voltages in hermetically sealed modules. The assumption is that some compounds from the adhesive are available to induce migration or that such elements enter the system before sealing.

In addition, the insulating gap between the ICA on component terminations may have been much smaller than intended. Therefore, the electrical field intensity over the diminished gap may be high.

The best means to minimize the risk for silver migration are (a) curing the ICA fully, (b) maintaining the designed gap between ICA on pads, and (c) preventing any foreign substances from entering the assembly. In other words, process parameters and stability as well as cleanliness are essential in achieving reliable ICA interconnections.

Process Inaccuracies/Errors - Accurately dispensing or stencil printing ICA is of highest importance to achieve reliable interconnections. The correct amount of the adhesive is also needed. Typical solder joints are self-aligning when the solder is molten. Unfortunately, this is not the case with ICAs. It is possible to create shorts by dispensing or printing the ICA incorrectly as the ICA stays exactly where it has been placed. On the other hand, too much adhesive may cause shorting when the components are placed on the ICA. Excess ICA may be squeezed to contact the adjacent pad, terminal, or ICA.

For ACAs, particle flow during the bonding process is important. The particles should not clog the spaces between adjacent pads nor flow away from the pads. The former poses a risk for shorting as the particles may gather in such amounts that pads are connected. This is easy to confirm in the case of chip-on-glass or flex-on-glass interconnections simply by looking through the glass. It is the role of process developers to ensure that proper flow occurs during the process.

Particle Size and Particle Count - If the ACA particle count is too high, it is possible that shorting will occur when the particles clog between pads as described in the previous section. On the other hand, too large particles result in a similar effect. One must check that the particle count and size of the ACA is suitable for the particular application. In addition, some ACA manufacturers have solved this problem in different ways. Sony Chemicals developed particles that have an insulating coating over the particle. The coating breaks when pressure is applied and will conduct from pad to pad. Particles remain insulating even if they do touch each other. Hitachi Chemicals developed an ACA with two layers, one insulating and the other particle-containing. This layered structure affects the flow of particles optimizing the number of particles on pads and minimizing particle clogging.

/ SUMMARY

Conductive adhesives are lead-free materials with a low temperature process capability. Anisotropic adhesives enable very high interconnection pitches. Because their performance meets the requirements of many applications, conductive adhesives offer solutions for many designs.

The design team is naturally interested in reliability of conductive adhesives and how this meets their design targets. It is extremely important to understand the failure mechanisms that may occur with conductive adhesives. This enables the design team to minimize stresses and to select the correct adhesive for their product. In addition, they will be able to select tests that will stress the adhesive interconnections in a way that gives information of the performance life.

To make successful conductive adhesive interconnections, the designers must pay attention to three items. First, know the expected stresses that will occur in use and select the conductive adhesive accordingly. Second, design the equipment in a way that minimizes stresses on the conductive adhesives. Third, ensure that the production department understands how conductive adhesives should be processed and that they are capable of controlling the process at proper levels.

For more information, and to request a quote from our Ansys Reliability Engineering Services Team, visit: <https://upl.inc/a5b0679>

/ REFERENCES

1. P. Savolainen, "Display Driver Packaging: ACF Reaching the Limits?", Proc. of 9th International Symposium on Advanced Packaging Materials, Processes Properties and Interfaces, 24-26 March 2004, Atlanta, GA, USA, pp. 7-10.
2. P. Savolainen, "Solder-filled anisotropic conductive adhesives in electronic interconnections", Thesis for the degree of Doctor of Technology, Helsinki University of Technology, Espoo, 1996.
3. H.J. Neuhaus, C.E. Bauer, "Alternatives to Solder in Interconnect, Packaging, and Assembly", J. of Surface Mount Technology, Vol. 26, Issue 1, 2013, pp. 31-36.
4. J.E. Morris, "Conduction mechanisms and microstructure development in isotropic, electrically conductive adhesives", Conductive Adhesives for Electronics Packaging, ed. J. Liu, Electrochemical Publications, 1999, pp. 37-77.
5. J. Liu, P. Lundström, "Manufacturability, reliability and failure mechanisms in conductive adhesive joining for Flip Chip and surface mount applications", Conductive Adhesives for Electronics Packaging, ed. J. Liu, Electrochemical Publications, 1999, pp. 212-255.
6. L. Frisk, "Reliability of Anisotropic Conductive Adhesive Bonded Flip Chip Joints on Organic Substrates", Tampere University of Technology, Publication 673, Tampere, 2007.
7. J. Liu, O. Salmela, J. Särkkä, J.E. Morris, P-E. Tegehall, C. Andersson, Reliability of Microtechnology – Interconnects, Devices and Systems, Springer publisher, 2011, p. 79.

ANSYS, Inc.
Southpointe
2600 Ansys Drive
Canonsburg, PA 15317
U.S.A.
724.746.3304
ansysinfo@ansys.com

If you've ever seen a rocket launch, flown on an airplane, driven a car, used a computer, touched a mobile device, crossed a bridge or put on wearable technology, chances are you've used a product where Ansys software played a critical role in its creation. Ansys is the global leader in engineering simulation. We help the world's most innovative companies deliver radically better products to their customers. By offering the best and broadest portfolio of engineering simulation software, we help them solve the most complex design challenges and engineer products limited only by imagination.

Visit www.ansys.com for more information.

Any and all ANSYS, Inc. brand, product, service and feature names, logos and slogans are registered trademarks or trademarks of ANSYS, Inc. or its subsidiaries in the United States or other countries. All other brand, product, service and feature names or trademarks are the property of their respective owners.

© 2022 ANSYS, Inc. All Rights Reserved.