

Electromagnetics Comes Through in the Clutch

BorgWarner engineers meet a tight deadline in optimizing the design of a revolutionary variable-torque clutch for all-wheel-drive vehicles.

By Chris Kurmaniak, Senior Design Release Engineer, BorgWarner TorqTransfer Systems, Michigan, U.S.A.

All-wheel automotive drive systems have evolved dramatically, becoming increasingly popular in an expanding range of vehicles. The technology began several years ago with relatively simple devices that would positively engage and disengage a vehicle's secondary axle with the main transmission and driveline. Systems are now more complex, with sophisticated controllers that continuously monitor vehicle conditions and actively adjust driveline torque balance to enhance vehicle stability and handling. These systems are also integrated seamlessly with the operation of the engine, transmission, anti-lock brakes and a myriad of other vehicle powertrain and safety subsystems.

One of the most recent advances in all-wheel-drive systems has been made by BorgWarner TorqTransfer Systems (TTS) — a leading global designer and producer of transfer cases and torque management devices for all-wheel-drive passenger cars, crossover vehicles, sport-utility vehicles and light trucks. The company recently developed the electromagnetically actuated NexTrac™ active all-wheel-drive system, which provides a slipping connection with varying levels of torque transmission between the front-wheel-drive transmission and rear axle.

BorgWarner TTS engineers initially attracted customer interest in NexTrac with concept-level hardware. The challenge then was to provide a set of production prototypes for a customer vehicle in three months. This required

re-engineering and optimizing the device's electromagnetic solenoid actuator, assuring reliability and proper function for a wide range of operating environments. In parallel, engineers had to provide guidance for the design, tooling and validation of the manufacturing processes.

Using electromagnetic capabilities in ANSYS Multiphysics software, engineers were able to achieve these goals, quickly evaluating design alternatives, optimizing device operation through simulation, and studying the impact of different material properties,

manufacturing processes, operational environments and other design variables. This minimized hardware prototype testing and enabled BorgWarner to subsequently land the contract and quickly launch a new robust product with market-leading performance.

NexTrac communicates with the vehicle's electrical bus and is modulated by a BorgWarner-supplied electronic control unit (ECU) containing proprietary control algorithms. According to the level of electrical current provided, an electromagnetic solenoid actuator compresses clutch plates. This action

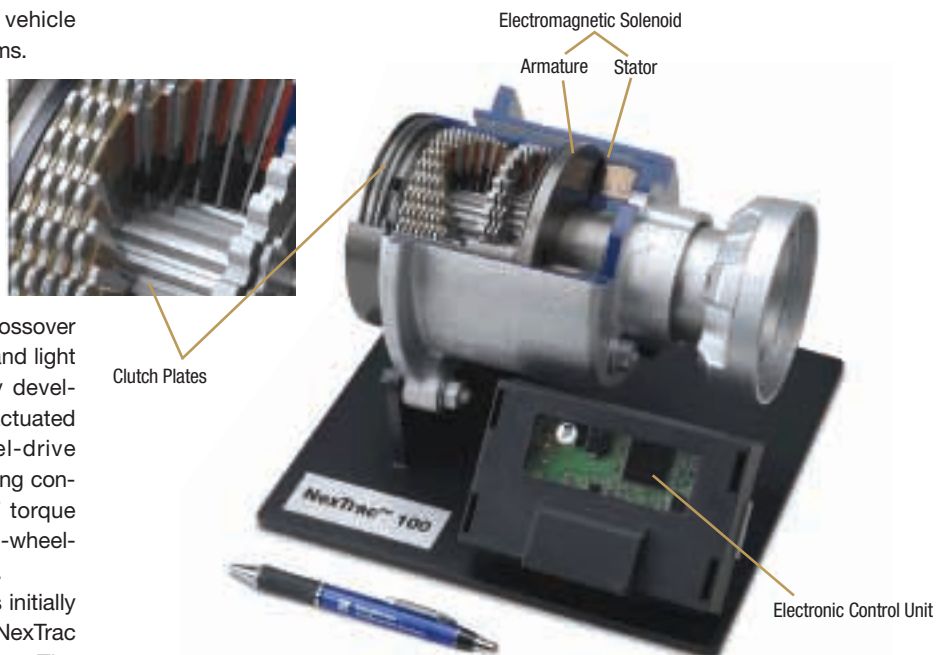

Based on electrical current from an electronic control unit (ECU), the armature of an electromagnetic solenoid actuator moves laterally to compress clutch plates separated by an organic friction material, thus applying required torque to the rear axle. The stator (containing the coil winding) is bolted inside an aluminum casting fixed to the vehicle's rear axle.

applies the required torque to the rear axle, enabling smooth engagement, exceptional torque accuracy and quick performance response at a relatively low cost. Engineers from BorgWarner used software from ANSYS in studying the many design constraints and nonlinearities associated with the stator and armature that comprise the device's electromagnetic solenoid actuator — the core element of NexTrac operation.

The engineering team used simulation in designing the various elements of the actuator to meet a range of performance criteria. Fundamentally, the actuator must achieve a specified maximum force (which dictates the maximum clutch torque of the system) within the size and power consumption constraints specified by the vehicle manufacturer. It must also reach its maximum force within a minimum amount of time and proceed to maximum force bounded by a force-to-electrical-current linearity requirement. The assembly must be designed robustly with respect to temperature and manufacturing variations. It must also survive a multitude of durability test schedules and vehicle level validation testing, and accomplish all objectives at minimum weight and cost. The ANSYS Multiphysics technology enabled BorgWarner engineers to quickly encompass all these important design constraints and nonlinearities.

During the simulation process, engineers meshed and analyzed the concept-level actuator to study electromagnetic performance, identify key design deficiencies and guide development toward an optimal design. They then selected important geometry features, which were automatically iterated and meshed by custom script programs generated within the ANSYS Multiphysics software environment.

One major advantage of the custom script feature was that it enabled coil winding characteristics to be integrated into the design permutation.

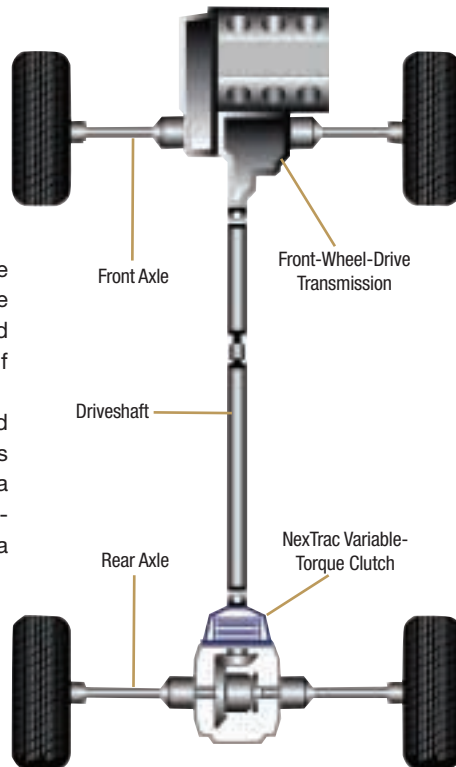

NexTrac active all-wheel-drive system provides a slipping connection with varying levels of torque transmission between the vehicle's front-wheel-drive transmission and the rear axle.

The ability to study the balance of magnetic circuit design (primarily flux density and the number of coil windings that would fit in the coil package) was extremely valuable. The engineering team also employed custom scripts to adjust temperature and material properties in validating the design under vehicle and manufacturing conditions. In addition, key dimensions — known for problems or difficulty in manufacturing — were permuted to study their effect on system performance before prototypes were produced.

The flexibility of the material property specification process proved to be very helpful throughout the project. Like many simulation problems, accurately representing nonlinear material behavior is vitally important to producing relevant results. This is particularly true in the estimation of force developed in electromagnetic

structures. Software from ANSYS enabled BorgWarner TTS to move forward quickly by including B-H nonlinear material property data into analysis models and comparing results with linear and native "reference steel" results.

The efficiency and interactivity of this process enabled analysts to go through multiple what-if iterations in comparing behavior of alternative materials.

Another valuable feature of the technology from ANSYS was the ability to analyze the design's response in the time domain. Through the design permutation process, BorgWarner engineers evaluated actuator reactions to typical controller inputs and used them as a tool for optimization. This enabled them to balance static design metrics with metrics of dynamic response. This feature is particularly important for products controlled in real time.

Through successful analysis and the ability to provide design direction to its sub-suppliers, BorgWarner TTS was able to meet customer deadlines and deliver a highly refined actuator design for maximum force capacity, improved linearity, reduced response time and reduced power consumption. In this way, ANSYS Multiphysics software enabled BorgWarner TTS to quickly deliver next generation NexTrac technology and meet the demands of a growing all-wheel-drive market. ■

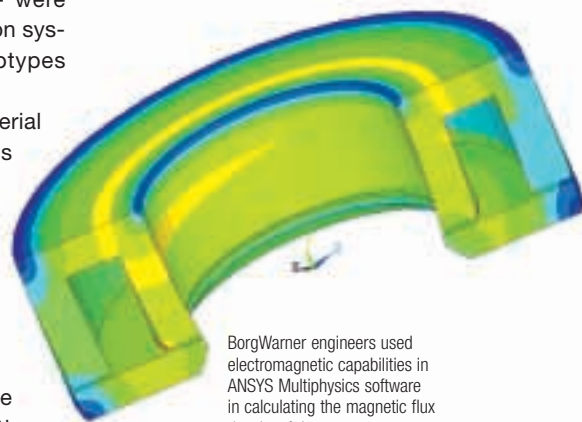

BorgWarner engineers used electromagnetic capabilities in ANSYS Multiphysics software in calculating the magnetic flux density of the armature.