

Peregrine Consulting, Inc.

Aerospace

United States of America



www.PeregrineConsulting.com



ANSYS® Mechanical™

Overview

Peregrine Consulting, Inc. provides design and analysis consulting services for the aerospace industry in areas such as turbine engine development, unmanned aerial vehicle design, engine systems integration and fatigue life studies. In one major project, the company has been engaged by the U.S. Air Force to investigate the feasibility of performing real-time stress and life analysis of jet aircraft engine turbine components based on as-flown conditions. Called condition-based maintenance (CBM), the approach would provide a reliable prediction of remaining component life for individual aircraft engines (tracked by serial number) by analyzing as-manufactured information and measurable data from each flight including turbine rotor speeds and engine thermodynamics. This CBM approach holds the potential to significantly lower lifecycle costs by scheduling maintenance before costly engine damage occurs from component field failures. In addition, reliable prediction of component life allows for the realistic reduction of overly large safety factors typically applied in calculating the expected life of critical components. Researchers at Peregrine Consulting determined that the most suitable technology to use as a basis for such a lifecycle cost management tool is finite element analysis (FEA).

Testimonial

"When Peregrine Consulting set about developing ground-breaking technology for aircraft turbine engine lifecycle cost management, we chose ANSYS as a core element in the approach. It was the preferred software because of its advanced simulation and parallel processing distributed solution capabilities, as well as its long-standing solid reputation as a veteran of aircraft turbine analysis and its use for decades as the tool of choice at turbine OEMs. In this selection, we were confident that ANSYS could provide the simulation capabilities we require — now and in the future — with their continuing commitment to being first-to-market with new performance-enhancing features."

David Stapp
President

Peregrine Consulting, Inc.

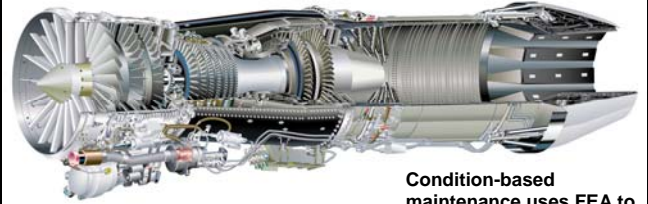

Condition-based maintenance uses FEA to predict component life for components in jet turbine engines such as the F414 powerplant for the F-18E/F Superhornet aircraft.

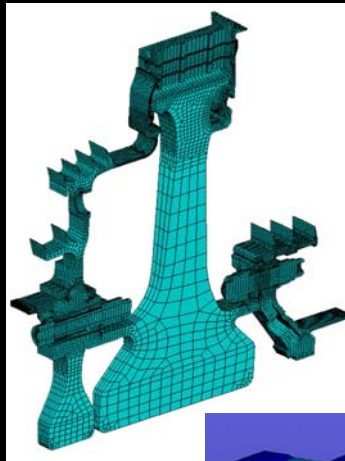

Complex model of the F414 aircraft engine high-pressure turbine rotor was created through ANSYS pre-processing capabilities.

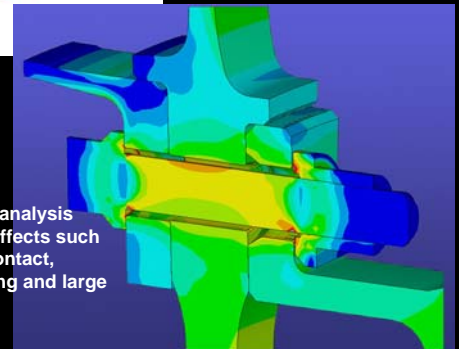

Detailed rotor analysis accounts for effects such as frictional contact, stress-stiffening and large deformations.

Challenge

Calculating fatigue damage for each engine component and each aircraft flight represents a significant undertaking, especially since the method is intended to apply to all aircraft of a given class: in this case, the F414 turbine engine for the F-18E/F Superhornet aircraft. For such a program, a huge amount of information must be managed, including the ongoing condition of engine parts, key data on aircraft performance, engine parameters for each flight and analysis results. Analysis models are extremely large, with millions of degrees-of-freedom requiring lengthy solution times. Moreover, simulation involves numerous complex, multi-attribute effects such as frictional contact, stress stiffening and large deflections of parts.

Solution

The challenges were overcome through the use of ANSYS Mechanical in combination with the TFLAMES data processing and process management program developed by Peregrine Consulting. TFLAMES screens and converts suitable data for ANSYS, which performs the required frictional-contact rotor assembly stress and thermal analysis. A key feature in the project was the Distributed ANSYS capability to run solutions efficiently in parallel across multiple CPUs. Significant speed-up was gained with the entire solution running in parallel including stiffness matrix generation, linear equation solving and results calculations. Solutions were run on i*hydra high-performance multi-processor servers designed by a Peregrine Consulting spin-off company to run ANSYS solutions of this magnitude efficiently.

Benefits

Peregrine combined:

- its own proprietary data management and fatigue damage prediction techniques
 - low-cost, high-performance servers
 - the ANSYS software capability to perform advanced structural simulation and process runs across multiple CPUs
- These provided the foundation for a lifecycle management system to run full rotor pseudo-transient analyses for aircraft engine parts in a period of time measured in hours rather than weeks — a major step forward in life assessment technology. In this manner, ANSYS enabled a practical method for reliably predicting fatigue life of components soon after aircraft flights, with the potential of scheduling appropriate maintenance to avoid costly damage from field failures.