

Making the Switch

Optimizing a seemingly simple electrical switch device assembly through simulation saves time and reduces costs.

By Arunvel Thangamani and Alok Pande, Schneider Electric, R&D, Global Technology Centre, Bangalore, India

A multiphysics simulation approach is used in electrical industries to predict product performance, to identify failure conditions and to perform design optimization. Product experimentation is very expensive, so repeated trials are discouraged. Therefore, using simulation to optimize products early in the design process is the preferred approach. Simulation can be of great benefit to product designers in these industries in meeting standards required by organizations such as Underwriters Laboratories (UL®) and the International Electrotechnical Commission (IEC®). Electrical and thermal simulations play a vital role in product development in a very wide range of product areas.

Schneider Electric set out to streamline some of its product design processes. A global specialist in energy management with operations in more than 100 countries, the company focuses on making energy safe, reliable and efficient. The organization’s Global Technology Centre (GTC) in Bangalore, India, works on product development and resource enhancement, and the resulting innovative products and technologies are available in markets across the globe.

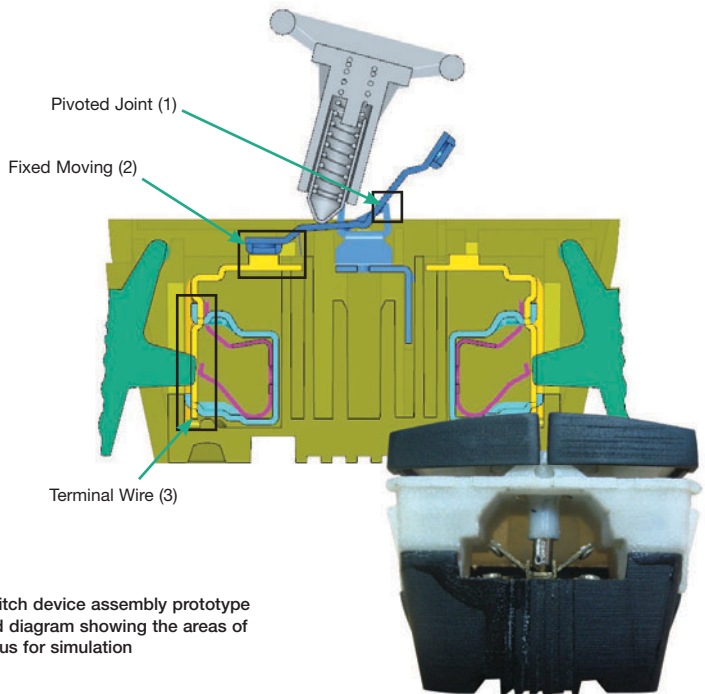

Switch device assembly prototype and diagram showing the areas of focus for simulation

To reduce costs and gain time in its product development process, the GTC uses ANSYS Icepak, ANSYS Multiphysics, ANSYS FLUENT and ANSYS Workbench technologies. In a recent project, researchers used ANSYS Icepak to perform thermal and electrical simulations on a wiring system switch device assembly

(installation and control switch) to determine the temperature generated due to joule heating as well as to define conductor and insulator specifications to effectively manage heat. The study extended into analyzing the effects of electrical-thermal contact resistances, the impact of radiation heat transfer in

Main Effects Plot for Temperature Rise
Data Means

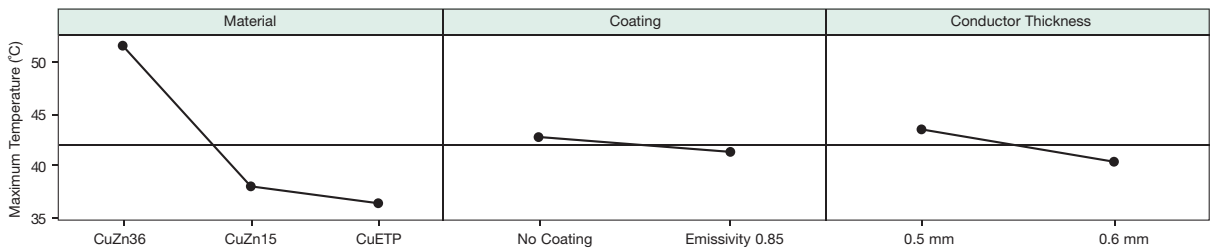

Results from the design of experiments for material, dimensions and radiation coating optimization

compact electrical devices, and the impact of overcurrent and high ambient temperatures on the product's thermal performance. The engineering team compared the results of the simulations with experimental results.

Installation and control switches are widely used in extra-low-voltage domains. These switches carry current in the range of 10 amps to 60 amps and act as the on-off mechanism for household lighting, industrial machines and other equipment. The switch device assembly that was studied consisted of multiple fixed terminal assemblies and one moving terminal that made or broke the contact. ANSYS Icepak simulation helped the team to achieve desirable temperatures with cost-effective materials and coatings. The software also helped to meet design specifications for contact pressure. Design of experiments (DOE) studies addressed changing dimensions, material options and radiation coatings as well as the impact of electrical contact resistance on the temperature of the product. Contact resistance was modeled as a conducting thin plate with a thickness in the order of microns. The material

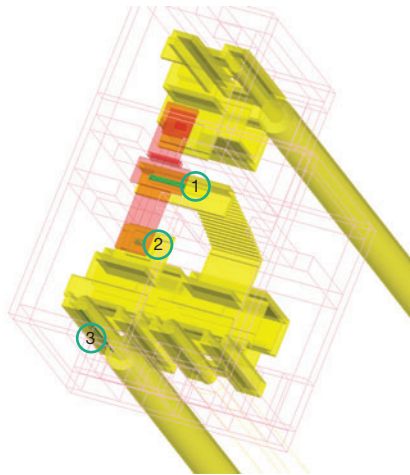

Simplified ANSYS Icepak model of the switch assembly

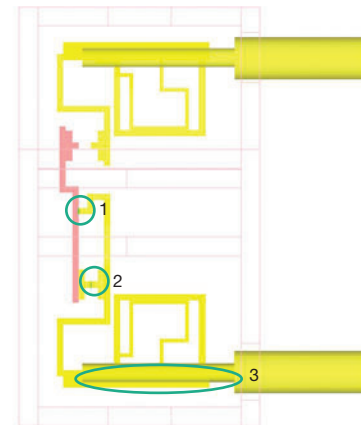

- | | |
|---|--|
| 1 | PJ - Pivot Joint |
| 2 | FM - Fixed Moving |
| 3 | TW - Ter-Wire (Wire Insertion Point at the Terminal) |

was assumed to be silver. The total power of the contact was computed using I^2R , in which I is the current specification of the product and R is the effective ohmic resistance across the contact, calculated from the experiment. R is calculated as the measured millivolts drop divided by I .

The robustness of the computation was assured by calibrating the finite volume model with the numerical constants for electrical contact resistance obtained from the lab tests.

Engineers employed the joule heating capability of ANSYS Icepak software to assign the electric properties and boundary conditions, such as electric resistivity, current specification and thermal coefficient of resistivity. Historical data for this product family is available in the form of millivolt drop measurements at the contact zone and at the input-output terminal. Using this information, the engineering team altered the boundary conditions at these specific locations. This contributed significantly to the accuracy of the temperature results. For radiation heat transfer, the surface-to-surface radiation model and the ANSYS Icepak automatic view factor computation feature were employed.

After the model was calibrated with the contact resistance data, a design optimization was performed using the parametric trials module in ANSYS Icepak. Critical design parameters were used as independent variables in the optimization: conductor alloy type, radiation coating emissivity and conductor dimension.

The DOE included 12 trials, and the full factorial design was used. The engineering team concluded that the impact of the material is much greater

Main Effects Plot for Temperature Rise
Data Means

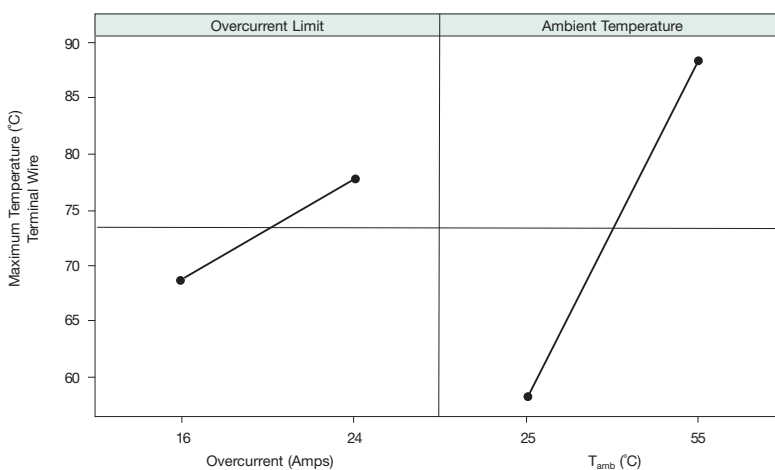

DOE results for the overcurrent and high ambient temperature study

Main Effects Plot for Maximum Temperature

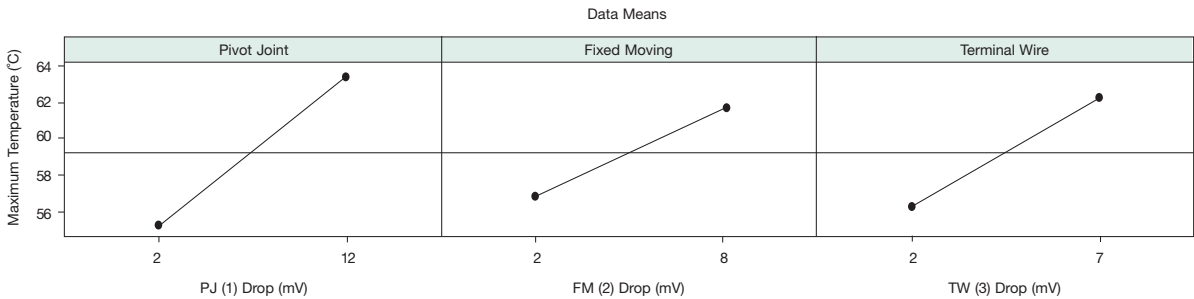

Results for the contact resistance study

than the other parameters. For example, radiation coatings and thickness caused less than a 5 degree Celsius (C) difference in the contact temperatures, but by using high-copper-content alloys, the temperature was reduced by approximately 15 degrees C. The team was able to identify the most cost-effective and thermal-efficient material as well as the appropriate specifications of radiation coatings for closed-environment heating. To have performed this extensive study through prototyping would have been very costly and time intensive.

In addition, engineers performed a DOE study to analyze the impact of contact resistance on the temperature rise. In such compact products, in which the conductor dimensions are small and the convection air flow is very limited, heating due to contact resistance is the main cause of overall temperature rise. Because the number of contacts is high (more than two in most cases), contact resistance heating is significant.

The two independent input parameters were contact resistance of the moving contact region at the

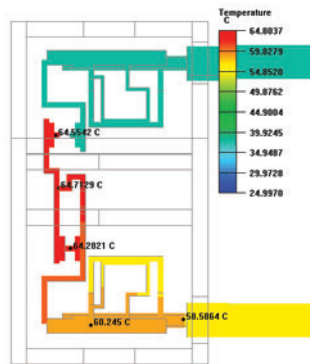

Temperature profile with the optimized material, dimensions and radiation coating

terminal (wire plugging) joint and contact resistance at the actuation mechanism contact joint. The DOE again included 12 trials and a full factorial design. The study helped the engineering team to decide which contact region was the greatest contributor to the temperature rise. Based on these results, the team recommended appropriate contact pressure and high-conductive-softening materials for that region. This DOE also provided insight into temperature increase in the contact zone with respect to the increase in millivolt drop, which helped to determine specific design limits on the aging of the contacts.

All the DOEs yielded transfer functions, which have been very useful in more recent design cycles of this product family. Verification of the transfer function was performed to ensure that the data points for the mathematical correlation matched well with the ANSYS Icepak results. More recent temperature rise experiments performed with the optimized design had only a 3 degree C difference, which increased confidence in the simulation process.

At a later time, the same model was used to predict the impact of higher ambient temperatures as well as higher current flowing from the line toward the load. The results helped the design team to determine the maximum operating points in the electrical distribution line.

The ANSYS Icepak results gave the Schneider Electric team confidence that the same modeling approach could be applied to the entire product family. This process reduces the number of prototypes and tests, and it has decreased the time for this product development by 30 to 40 percent and the cost of prototypes by approximately 30 percent. ■