

# ANSYS® + Emhart

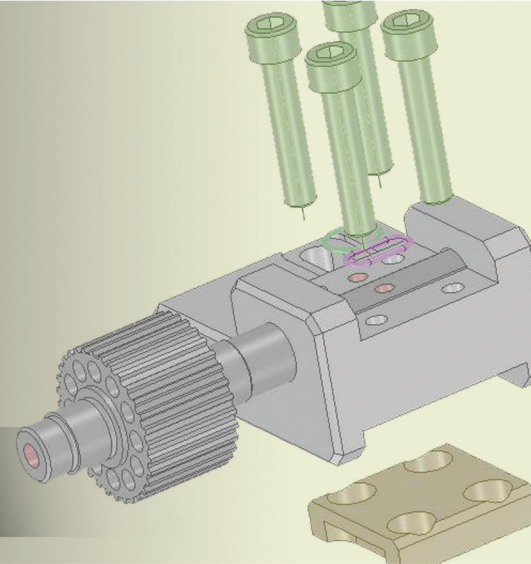

*"I've gained back at least 50 percent of my time with ANSYS SpaceClaim and am now able to focus on analysis and delivering the optimal design changes to new concepts or existing machinery. Pre-processing is no longer the limiting factor. I can access in-house and outside computing resources and have as many as eight simulations running at the same time!"*

**Pierre Ngankeu**  
Senior Mechanical Engineer,  
Emhart Glass Research Center

## Emhart Glass Reduces the “Heat” on Bottle Creation With ANSYS® SpaceClaim

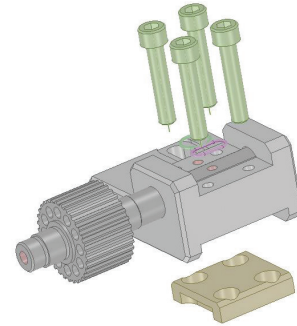

Pierre Ngankeu is a Senior Mechanical Engineer in the Process Automation & Simulation group at Emhart Glass Research Center. The Center includes a complete production line, enabling Emhart engineers and researchers to test new ideas in an industrial environment. The successful concepts can then be translated to the Equipment Innovations team to address challenges such as furnace variations, glass property changes, and cooling-wind fluctuations. Pierre performs multi-physics analysis on design concepts, with an emphasis on fluid dynamics and heat transfer during the molding process. Every bottle has different geometries, shapes, and challenges. The thermal distribution in the mold must be carefully controlled to optimize production rate, consistency, and quality.

### Design Challenge

Modeling with Extremely Complex Heat, Fluid, and Air Issues Pierre performs analysis on glass molding concepts, examining the balance of heating and cooling in a mold, using proprietary models of glass viscosity and of conduction and convection between the mold and glass domains and the glass and air domains.

Modeling and pre-processing have been the most time-consuming part of the simulation process. Pierre has to work with foreign CAD data, deal with meshing and density issues, and create the flow domain before analysis. The process could take days for each simulation and usually he had to delete the whole model and create a new one.

For analysis, Pierre uses POLYFLOW from ANSYS. Among other features, POLYFLOW handles radiation and can successfully model the open surfaces between air and glass.

“The mechanical designers create new concepts and it is my job to destroy them and find out what will and won’t work,” said Pierre Ngankeu, Senior Mechanical Engineer, Emhart Glass Research Center.

### Simplifying Complex Model Preparation with ANSYS SpaceClaim

Pierre provides analysis on new product concepts and also works with the sales team to field special, customer challenges.

The complexity in preparing models for simulation includes the fact that there usually is not a lot of data available for many of the processes. An example would be the creation of a model to test a metal plunger used in the glass forming process. The plunger is a tube, with 32 holes in the body and one on top, which must carefully distribute air to cool the glass. Emhart’s Plunger Process Control system monitors the plunger during the glass forming process to detect issues with alignment, wear, dirt, lubrication, and other environmental and production challenges. For Pierre to analyze the plunger model, he had to create fluid and metal domains which involved deleting the volume and rebuilding the model from the ground up – a process that took over a full day. Bigger models became even more time consuming.

“I don’t need rounds or sharp edges. So when preparing models, I had to get rid of sliver faces, gaps, and other model elements prior to analysis. With ANSYS SpaceClaim, I can prepare models in less than 30 minutes, enabling me to quickly perform basic volume extraction and de-featuring, regardless of the size of the model. The days of deleting a model and starting all over are gone.” Pierre Ngankeu

While Pierre is experienced in working with Pro/ENGINEER, in the past he would just go into the program to extract the information he needed. Then, he would have to turn that data into a STEP or ACIS file before starting to prepare the model for analysis. With ANSYS SpaceClaim, that step has been completely eliminated.

“I’ve gained back at least 50 percent of my time with ANSYS SpaceClaim and am now able to focus on analysis and delivering the optimal design changes to new concepts or existing machinery. Pre-processing is no longer the limiting factor. I can access in-house and outside computing resources and have as many as eight simulations running at the same time!” Pierre Ngankeu

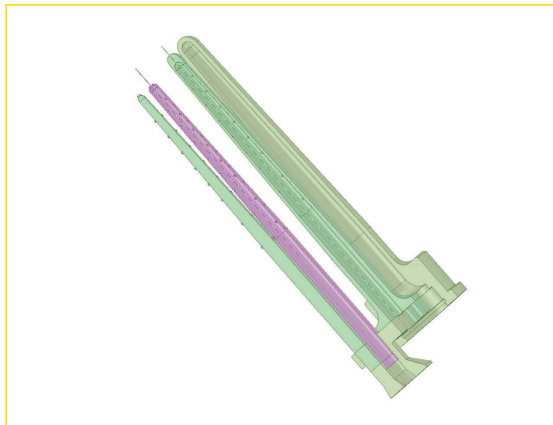
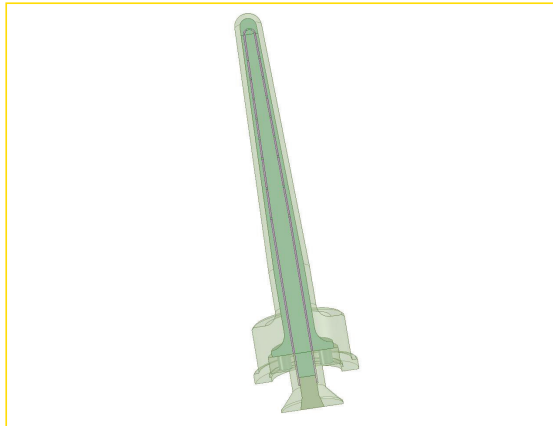

When conducting a flow analysis, the plunger, cooling tube parts, and air volume are created using ANSYS SpaceClaim.

ANSYS SpaceClaim’s integration with ANSYS enables the changes that Pierre made in ANSYS SpaceClaim to populate ANSYS automatically. Where many of the designs are rotationally symmetric, Pierre can take advantage of the simplicity of ANSYS SpaceClaim’s cross-sectional creation and editing capabilities. Once optimized, he sends the solids back to the design team using Pro/ENGINEER.

“I’m a heat transfer guy. With ANSYS SpaceClaim’s cross-section capabilities, I’m able to easily understand what is going on. I provide feedback on issues such as temperature distribution with air flow rates. ANSYS SpaceClaim has enabled me to take on more projects and be much more efficient.” Pierre Ngankeu

#### About Emhart Glass Research Center

Emhart Glass, a Bucher company, is the world’s leading international supplier of equipment, controls, and parts to the glass container industry, including everything from soda bottles to pharmaceutical containers. Emhart Glass Research Center focuses on developing enhanced glass-forming methods, increasing automation and improving yields.

**ANSYS, Inc.**

[www.ansys.com](http://www.ansys.com)

[ansysinfo@ansys.com](mailto:ansysinfo@ansys.com)

866.267.9724